

STEP 6: MOUNTING THE FLAT PANEL TELEVISION TO THE PLATE

Warning: Some televisions may require 2 people to lift! We are not responsible for personal injury or product damage.

First choose the desired height then hook the Monitor Brackets (17) over the top of the Plate (16) as shown in the diagram. Finally fix the brackets into position with two screws. Put four covers on the base.

STEP 6

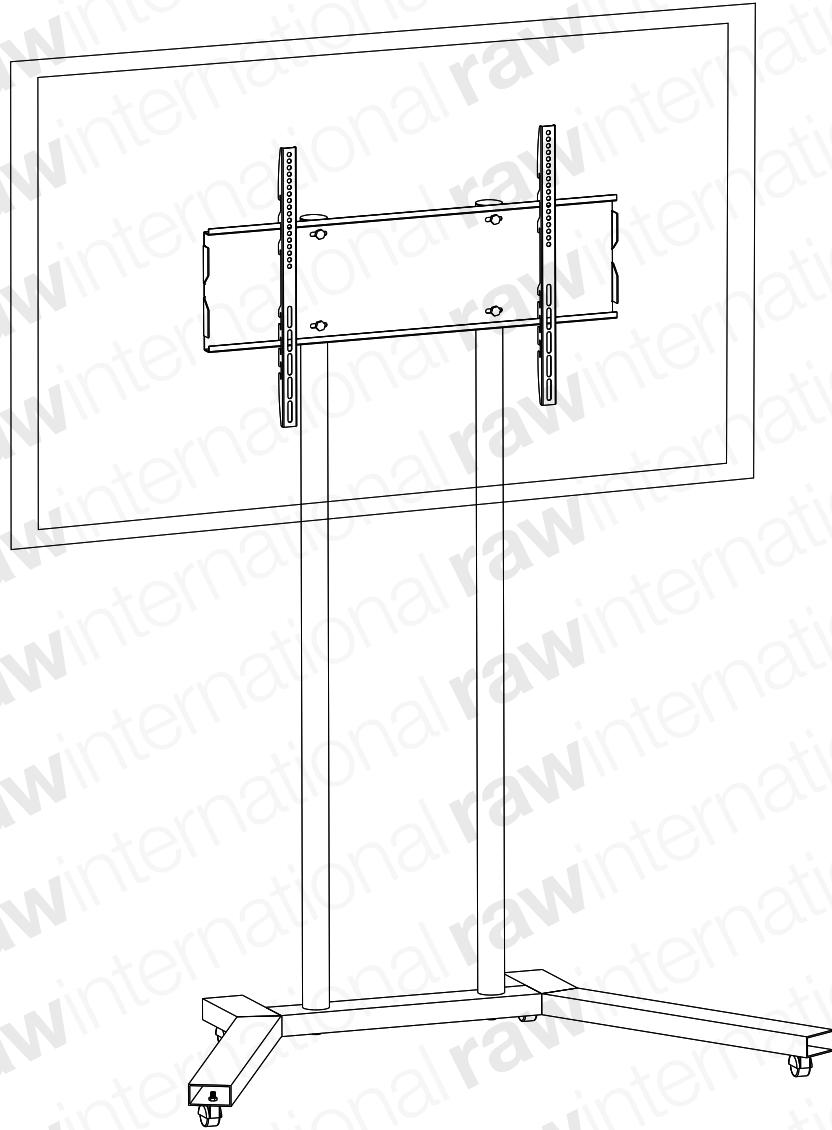

rawinternational

CONSULT AUTHORISED SERVICE PERSONNEL FOR THE INSTALLATION OF THIS UNIT. INSTRUCTIONS MUST BE FOLLOWED PRECISELY FOR SAFE AND STABLE INSTALLATION. RAW INTERNATIONAL ARE NOT LIABLE FOR ANY DAMAGE OR INJURY CAUSED BY MISHANDLING OR IMPROPER INSTALLATION.

TRS1 INSTRUCTION MANUAL

LIST OF COMPONENTS

No.	Description	Quantity	No.	Description	Quantity
1	Base	1	15	M8 Lock Washer	4
2	Wheel with Brake	4	16	Plate	1
3	Metal Tube	2	17	Monitor Bracket	2
4	Square tube cover	4	18	M5x12 Bolt	4
5	M12x60 Bolt	2	19	M5x30 Bolt	4
6	M8x65 Bolt	4	20	M6x12 Bolt	4
7	Wrench Set	1	21	M6x35 Bolt	4
8	M10 Gusset Nut	4	22	M8x16 Bolt	4
9	M8 Gusset Nut	4	23	M8x40 Bolt	4
10	M12 Washer	2	24	M4/M5 Spacer	4
11	M10 Washer	4	25	M6/M8 Spacer	4
12	M8 Washer	4	26	M4/M5 Washer	8
13	M12 Lock Washer	2	27	M6/M8 Washer	4
14	M10 Lock Washer	4			

STEP 1: INSTALL THE FOUR WHEELS ON THE BASE

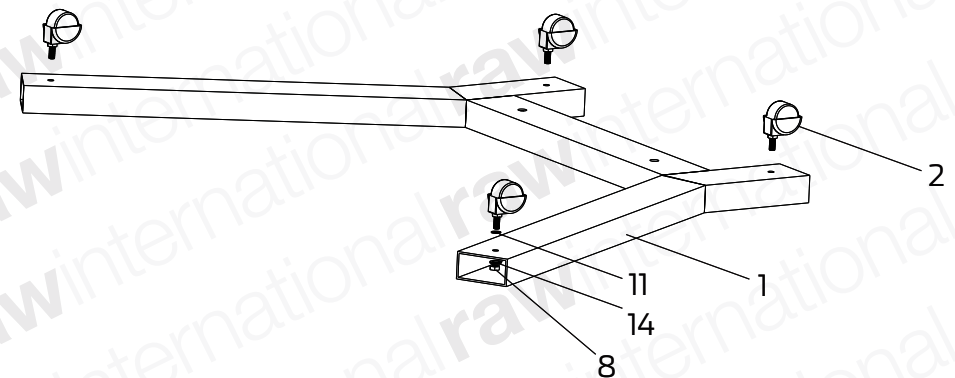

STEP 2: CONNECT TWO TUBES TO BASE

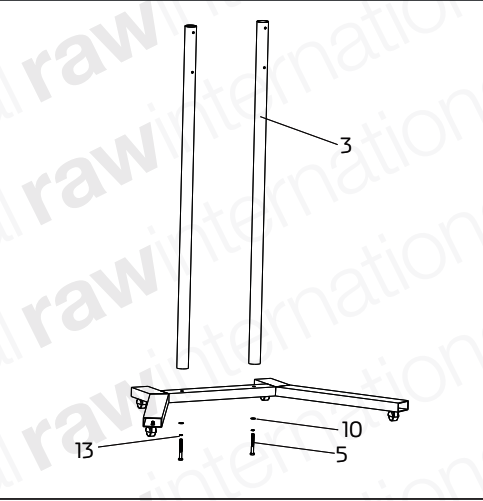

STEP 3: MOUNT THE BRACKET ON THE TUBES

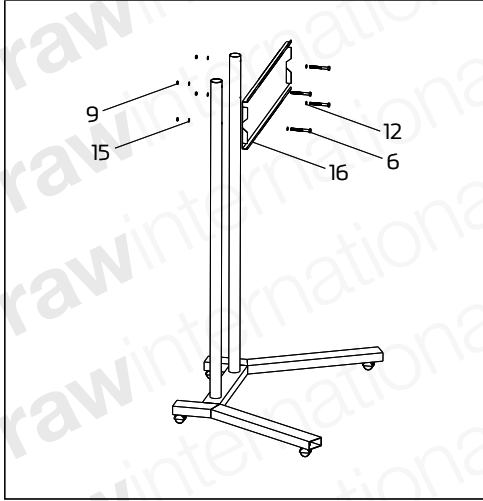

STEP 5: MOUNTING MONITOR BRACKETS TO A TELEVISION WITH A CURVED BACK, RECESSED THREADED INSERTS OR ANY OTHER OBSTRUCTION

First, determine the diameter of the Bolt (19,21,23) your TV requires by hand threading them into the threaded insert on the back of the TV. If you encounter any resistance, please stop immediately! Once you have determined the correct diameter, see the appropriate diagram below. You will thread the Bolt through the Washer (26,27), the Monitor Bracket (17), a spacer (24,25) and finally into the TV. For the M4 or M5 diameter bolt, you will need another M4/M5 Washer between the Monitor Bracket and the Spacer. Make sure the Monitor Brackets are vertically centered and level with each other.

STEP 4: MOUNTING MONITOR BRACKETS TO A TELEVISION WITH A FLAT BACK

Check the diameter of Bolt (18,20,22) your TV requires by hand threading them into the threaded insert on the back of the TV. If you encounter any resistance, please stop immediately! Once you have determined the correct diameter, see the appropriate diagram below. You will thread the Bolt through the appropriate Washer (26,27), the Monitor Bracket (17), and finally into the TV. Make sure the Monitor Brackets are vertically centered and level with each other.

STEP 4

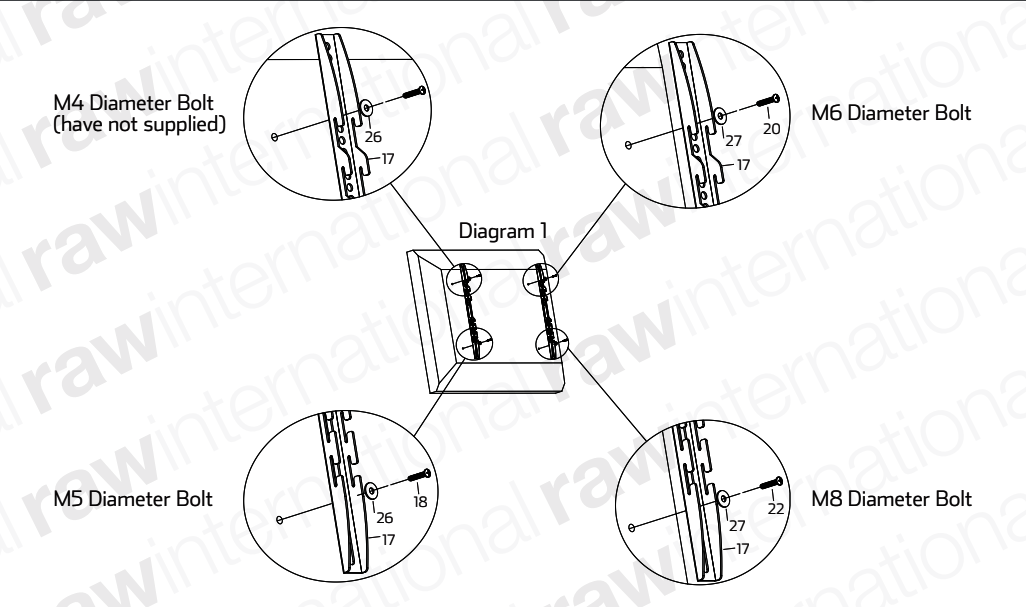

STEP 5

